

NOTICE 07-001

It has come to the attention of the Foundation that some of the following Conbraco backflow prevention assemblies have been sold with check valve springs manufactured out of tolerance and are not approved. The assemblies affected include the following:

Double Check Valve Assembly

2-1/2-inch - Model 2 1/2DC, 2 1/2DC7, 2 1/2DC8, 2 1/2DCU

3-inch - Model 3DC, 3DC7, 3DC8, 3DCU

4-inch - Model 4DC, 4DC7, 4DC8, 4DCU

6-inch - Model 6DC, 6DC7, 6DC8, 6DCU

Double Check-Detector Assembly

2-1/2-inch - Model 2 1/2DCDA, 2 1/2DCDA6, 2 1/2DCDA7, 2 1/2DCDA8,
2 1/2DCDAU

3-inch - Model 3DCDA, 3DCDA6, 3DCDA7, 3DCDA8, 3DCDAU

4-inch - Model 4DCDA, 4DCDA6, 4DCDA7, 4DCDA8, 4DCDAU

6-inch - Model 6DCDA, 6DCDA6, 6DCDA7, 6DCDA8, 6DCDAU

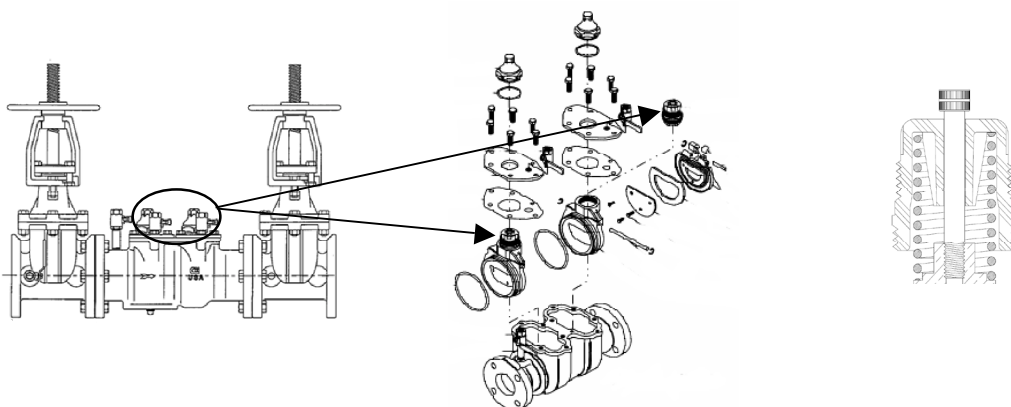

The improper check valve springs have too many spring coils, which will restrict the check valve clappers from opening to their normal fully open position. This will cause a higher pressure loss through the assembly at the flow rates above approximately 500 gpm. The springs are contained in the spring assembly modules for each check valve. (Note: Warning from Conbraco repair manual: The check valve spring is held in compression by the retainer bolt. The spring assembly should not be disassembled as serious injury could occur. The spring assembly is sold as a pre-loaded unit.)

The same spring module is utilized in all the sizes noted above, however, only the 6-inch assembly has a rated flow rate (Table 10-1, Manual-9th Ed) above 500 gpm.

Should you have an assembly affected by this situation please contact Conbraco at (704) 841-6000 for replacement spring assembly modules.